

BEFCO[®]

Operator's Manual

MOLE

Post Hole Diggers

100-512, 200-512, 300-512, 400-512

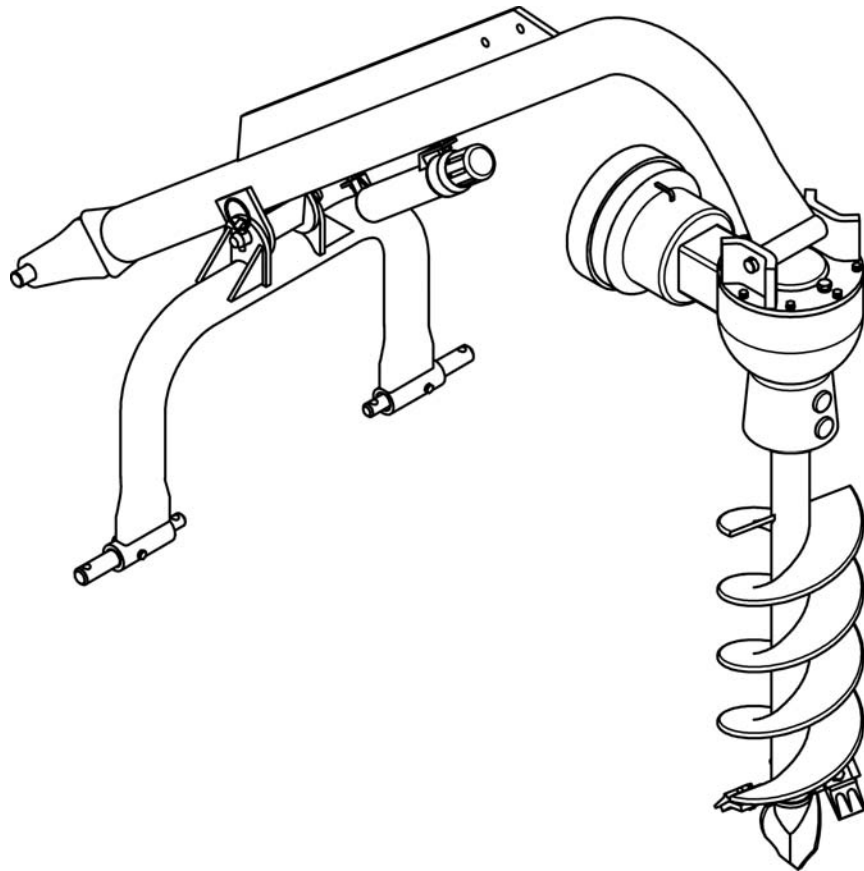

Before you begin use of equipment, read, understand, and follow all safety instructions in this manual.

The operator's manual is a technical service guide and must always accompany the machine.

Manual 960-125B

August 2017

SAFETY

Take note! This safety alert symbol found throughout this manual is used to call your attention to instructions involving your personal safety and the safety of others. Failure to follow these instructions can result in injury or death.



*This symbol means:
ATTENTION!
BECOME ALERT!
YOUR SAFETY IS INVOLVED!*

Signal Words

Note the use of the signal words DANGER, WARNING and CAUTION with the safety messages. The appropriate signal words for each have been selected using the following guidelines:



DANGER: Indicates an imminently hazardous situation that, if not avoided, will result in death or serious injury.



WARNING: Indicates a potentially hazardous situation that, if not avoided, could result in death or serious injury, and includes hazards that are exposed when guards are removed. It may also be used to alert against unsafe practices.



CAUTION: Indicates a potentially hazardous situation that, if not avoided, may result in minor or moderate injury.

INDEX

1 - GENERAL INFORMATION	4
1.01 - General	4
1.02 - Warranty Information	4
1.03 - Model and Serial Number ID	5
2 - SAFETY PRECAUTIONS	6
2.01 - Preparation	6
2.02 - Starting and Stopping	9
2.03 - Messages and Signs	10
3 - OPERATION	12
3.01- Operational Safety	12
3.02 - Set Up	13
3.03 - Pre-Operational Check	14
3.04 - Assembly and Attaching to the Tractor	14
3.05 - Start Up	18
3.06 - Transport	20
3.07 - Optional Down Pressure Kit	20
3.08 - Optional Hookup Stand	23
3.09 - Optional Positioning Handle	24
4 - MAINTENANCE	25
4.01 - Maintenance Safety	25
4.02 - Service	26
4.03 - Driveline	28
5 - REPAIR PROCEDURES	31
5.01 - Shear Bolt Replacement	31
5.02 - Suggested Spare Parts	31
5.03 - Storage	32
6 - TROUBLESHOOTING	33
7 - PRE-DELIVERY CHECKLIST	34
8 - WARRANTY	35

1 - GENERAL INFORMATION

Thank you and congratulations for having chosen our implement. Your new post hole digger is a technologically advanced machine constructed of high quality, sturdy components that will fulfill your working expectations.

Read this manual carefully. It will instruct you on how to operate and service your machine safely and correctly. Failure to do so could result in personal injury and/or equipment damage.

1.01 - General

The implement described in this manual is to be used with tractors with PTO at 540 rpm and clockwise rotation.



CAUTION: Always ensure that the coupling of the implement with the tractor is done at the same PTO speed and direction of rotation. Do not operate this implement at a PTO speed or direction of rotation other than that shown on the implement. Serious damage can occur to the machine and/or the operator.



CAUTION: Unless otherwise specified, all hardware is metric. Use only metric tools on metric hardware. Other tools that do not fit properly can slip and cause injury.



CAUTION: Right hand and left hand sides of the implement are determined by facing in the direction the implement will travel when going forward (see fig. 2).

1.02 - Warranty Information

Carefully read the Warranty section¹, detailing coverage and limitations of this warranty. **Warranty** is provided for customers who operate and maintain their equipment as described in this manual. Warranty registration is accomplished by the dealer by completing and forwarding the **Warranty Registration** form to the Company, along with a copy of the dealer's invoice. It is in your best interest to insure that this has been done.

Warranty does not cover the following:

1. Cleaning, transporting, mailing and service call charges.

¹ See Chapter 8 - Warranty.

2. Normal wear items such as auger point and teeth, bearings, hydraulic hoses, drivelines, shear pins, etc.
3. Depreciation or damage caused by normal wear, accidents, improper maintenance, improper protection or improper use.
4. The use of non-original spare parts and accessories.

Your Authorized Company Dealer has genuine parts in stock. Only these approved replacement parts should be used.

This limited warranty covers defective material and workmanship. The cost of normal maintenance or repairs for accidents or improper use and related labor will be borne by the owner.

1.03 - Model and Serial Number ID

Attached to the frame is an ID plate showing the model and the serial number. Record your implement model and serial number in the space provided below. Your local dealer needs this information to give you prompt, efficient service when you order parts.

BEFCO	1781 S. Wesleyan Blvd. – P.O. Box 6036 Rocky Mount, N.C. 27802 – U.S.A. Tel: 1.252.977.9920 Fax: 1.252.977.9718
MODEL:	<input type="text"/>
SERIAL:	<input type="text"/>
VERSION:	<input type="text"/>

2 - SAFETY PRECAUTIONS

Safety is the primary concern in the design and manufacture of our products. Unfortunately our efforts to provide safe equipment can be wiped out by a single careless act of an operator. As manufacturers of post hole diggers, we want to confirm to you, our customers, our concern for safety.

In addition to the design and configuration of equipment, hazard control and accident prevention are dependent upon the awareness, concern, prudence and proper training of personnel involved in the operation, transport, maintenance and storage of equipment. It is the operator's responsibility to read and understand all safety and operating instructions in the manual and to follow these.

Allow only properly trained personnel to operate the post hole digger. Working with unfamiliar equipment can lead to careless injuries. Read this manual, and the manual for your tractor, before assembly or operation, to acquaint yourself with the machines. It is the post hole digger owner's responsibility, if this machine is used by any person other than yourself, is loaned or rented, to make certain that the operator, prior to operating, reads and understands the operator's manuals and is instructed in safe and proper use. Review frequently the safety precautions for the post hole digger and tractor with all operators.

Our current production of machines include, as standard equipment, guards or shields for auger adapters, drivelines, input shafts, and safety signs. Older machines can be retrofitted to add these new guards or shields and, of course, safety signs. **If you have an older machine which does not have current standard safety equipment or if you are unsure, please contact your dealer about bringing your machine up to the current level of safety.**

Do not modify the equipment in any way. Unauthorized modifications may impair the function and/or safety and could affect the life of the equipment.

Do not exceed the limits of any equipment and operate only in daylight or good artificial light.

2.01 - Preparation



CAUTION: Working with unfamiliar equipment can lead to careless injuries. Read this manual, and the manual for your tractor, before assembly or operating, to acquaint yourself with the machines. It is the post hole digger owner's responsibility, if this machine is used by any person other than yourself, is loaned or rented, to make certain that the operator, prior to operating:

1. Reads and understands the operator's manual.
2. Is instructed in safe and proper use.



WARNING: The majority of accidents involve entanglement on the driveline or auger. The risk of entanglement becomes greater when you replace our shear bolts or auger retaining bolts with bolts longer than those specified by the manufacturer. This improper replacement occurs most often on machines that are loaned or rented to someone who has not read the operator's manual and is not familiar with a post hole digger.

1. This post hole digger is designed for one-man operation from the tractor seat. It is the responsibility of the operator to see that no one is within twenty-five feet (25') of the digger when it is started. Do not operate the digger with another person, small children, and/or pets near, or in contact with, any part of the digger, PTO driveline, or auger. Serious personal injury or death may result if any attempt is made to assist digger operation by hand. Stop operation whenever anyone comes within the operating area.
2. The use of this equipment is subject to certain hazards which cannot be protected against by mechanical means or product design. All operators of this equipment must read and understand this entire manual, paying particular attention to safety and operating instructions prior to using. If there is something in the manual which you do not understand, ask your supervisor or your dealer to explain it to you.
3. Most accidents occur because of neglect or carelessness. Keep all helpers and bystanders twenty-five feet (25') away from the operating digger. Only properly trained people should operate this machine. It is recommended the tractor be equipped with a Rollover Protection System (ROPS) and a seat belt. Always stop the PTO, set brake, shut off the tractor engine, remove the tractor key and allow auger to come to a complete stop before dismounting tractor. Never leave equipment unattended with the tractor running.
4. Please remember it is important that you read and heed the safety signs on the digger and the safety rules set forth. Clean or replace all safety signs if they cannot be clearly read and understood. Do not paint over, remove, or deface any safety decals on your equipment. They are there for your safety, as well as the safety of others. The safe use of this machine is strictly up to you, the operator.
5. All things with moving parts are potentially hazardous. There is no substitute for a cautious, safe-minded operator who recognizes potential hazards and follows reasonable safety practices. The manufacturer has designed this digger to be used with all its safety equipment properly attached, to minimize the chance of accidents. Study this manual to make sure you have all safety equipment attached.
6. If a safety shield is removed for any reason, it must be replaced before the machine is again operated. Always use and maintain in place all power take off guards furnished with the tractor as well as the power take off guards and shields furnished with the digger. Ensure the anti-rotation chain is secured to the hole in the driveline guard.
7. This digger is designed for use only on tractors with a 540 rpm power take off.

8. When use of hand tools are required to perform any part of assembly, installation, adjustment, maintaining, repairing, removal, or moving the digger, be sure the tools used are designed and recommended by the tool manufacturer for the specific task.
9. Personal protection equipment including hard hat, hearing protection, safety glasses, safety shoes, and gloves are recommended during assembly, installation, operation, adjustment, maintaining, repairing, removal, or moving the digger. Do not allow long hair, loose fitting clothing or jewelry to be around moving parts.
10. Always use two people to handle heavy, unwieldy components during assembly, installation, removal, or moving the digger.
11. Never place any part of your body where it would be in danger if movement should occur during assembly, installation, operation, maintaining, repairing, removal, or moving the digger.
12. Never place yourself between the tractor and the digger while the implement is in operation.
13. Do not walk or work under a raised digger or attachment unless it is securely blocked or held in position. Do not depend on the tractor hydraulic system to hold the implement or attachment in place.
14. A heavy load can cause instability of the tractor. Use extreme care during travel. Slow down on turns and watch out for bumps. The tractor may need front counterweights to counter balance the weight of the digger.
15. Never use alcoholic beverages or drugs which can hinder alertness or coordination while operating this equipment. Consult your doctor about operating this machine while taking prescription or over-the-counter medications.
16. Do not allow riders on the digger or tractor at any time. There is no safe place for riders.
17. Before you operate the digger, check over all pins, bolts, and connections to be sure all are securely in place. Replace any damaged or worn parts immediately.
18. Consult local utility companies to make certain there are no buried gas lines, electrical cables, etc., in the work area before beginning operation.
19. Do not allow anyone who is not familiar with the safety rules and operation instructions to use this post hole digger.
20. Never allow children to operate or be around this digger.
21. Use stabilizer bars, adjustable sway chains, or sway blocks on your tractor lift arms to keep the post hole digger from swinging side to side. Adjust as tightly as practical for best performance.
22. Never replace the shear bolt or auger retaining bolt with any length other than what is specified in this manual. A longer or protruding fastener is more likely to grab loose clothing or gloves, which can result in serious injury or death.
23. Clear the work area of objects, such as stones or branches, which might be picked up and thrown or entangled in the auger.
24. To prevent possible rapid wear of U-Joints and possible failure of drivelines, never lift auger more than 12" off the ground with PTO operating.
25. To prevent possible instantaneous driveline failure, never move digger from hole to hole or transport while auger is rotating. This could lead to injury from flying pieces of the failed driveline.

26. Do not operate digger on steep hillsides. When digging on uneven or hilly terrain, position the tractor with the post hole digger uphill. With the post hole digger downhill, the tractor could tip when attempting to pull the auger from its hole.
27. Never position the auger point by hand when the tractor is running.
28. Never position the auger point by putting your hands on the auger, gearbox, boom, or driveline.
29. Keeps body parts, hands, feet, hair, jewelry, and clothing away from all moving and/or rotating parts.
30. To prevent entanglement and possible serious injury or death, never use body weight to try to push auger into the ground.
31. Worn edges or a slightly rounded point can seriously affect auger penetration. Check for wear before each use. Replace as necessary.
32. Do not shovel dirt away from a rotating auger as the shovel can be caught and thrown by the auger.
33. Do not operate the post hole digger without all safety shields and guards in place.
34. Shut off PTO and wait for the auger to stop movement before transporting.
35. Always use care when operating a post hole digger.

2.02 - Starting and Stopping



1. Be sure that no one is near the machine prior to engaging or while the machine is working.
2. Be sure the tractor is in "Neutral" before starting engine.
3. Post hole digger operating power is supplied from tractor PTO. Refer to your tractor manual for PTO engagement and disengagement instructions. Always operate PTO at 540 rpm. Know how to stop the tractor and post hole digger quickly in case of an emergency.
4. When engaging PTO, the engine rpm should always be low. Once engaged and ready to start using, raise PTO speed to 540 rpm and maintain throughout operation.
5. Check the tractor master shield over the PTO stub shaft. Make sure it is in good condition and fastened securely to the tractor. Purchase a new shield if old shield is damaged or missing.
6. After striking an obstacle, disengage the PTO, shut the tractor down and thoroughly inspect for damage before restarting.
7. Never engage the PTO until the post hole digger is in the down position and resting on the ground. Never raise the post hole digger until the auger has come to a complete stop.
8. Take all possible precautions when leaving unit unattended: Disengage PTO, set parking brake, stop engine, and remove key from ignition. Park in level area.

2.03 - Messages and Signs



CAUTION: Observe and follow all safety signs. Never operate the machine near people or pets. Replace any missing or damaged safety labels.



1. Read and adhere to all safety and operating decals on this machine (**see fig. 2**).
2. Before dismounting tractor: Allow moving parts to stop, stop engine, set brake and remove the key of unattended equipment.
3. Keep away from rotating auger and driveline.
4. Keep guards and shields in place and in good condition.
5. Do not use with bystanders in area.
6. Allow no riders on the tractor.
7. Allow moving parts to stop before repair.
8. Securely support post hole digger before performing any maintenance.

Additional warning and operating decals are available at no extra charge. Please specify model and serial number when ordering.

Fig. 2- Safety decals - driveline; replace immediately if damaged.

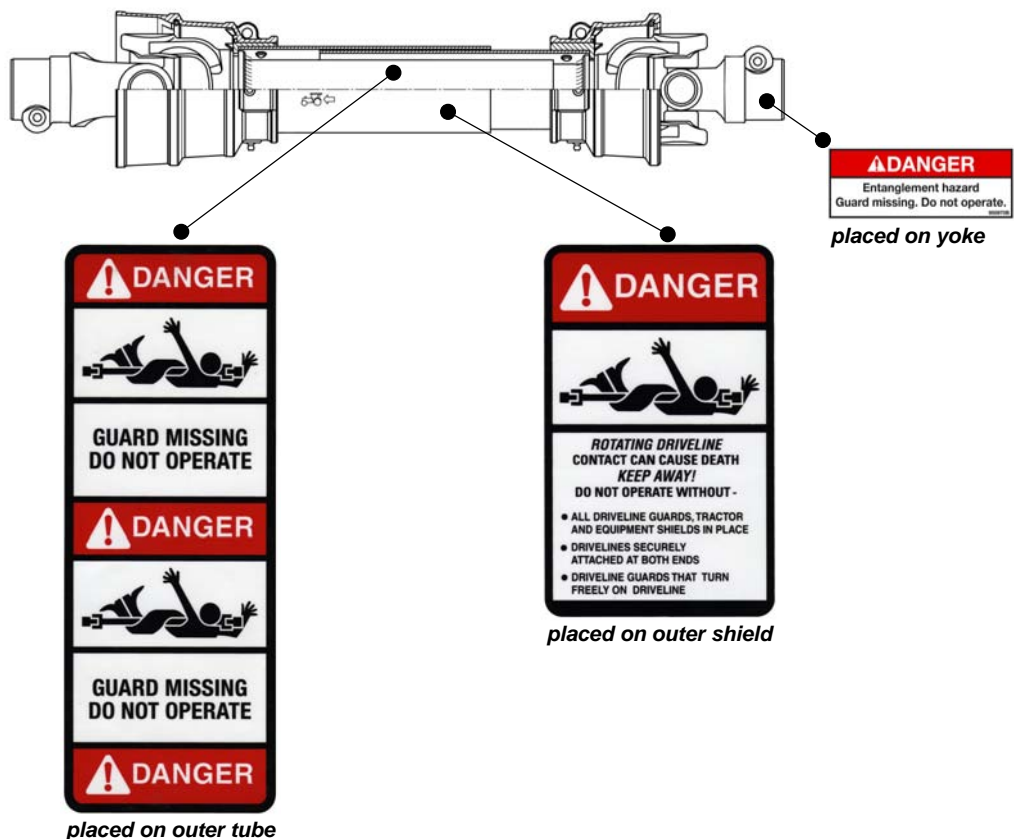

Safety decals - implement; replace immediately if damaged.



**Know what's below.
Call before you dig.**

950-9628

⚠ DANGER



Rotating auger can cause serious injury or death! Keep away!

9502128

⚠ DANGER

Entanglement hazard can cause serious injury or death. Guard missing when this is visible. Do not operate.

Si no entiende inglés, se prefiere que busque a alguien que interprete las instrucciones para usted.

9502128

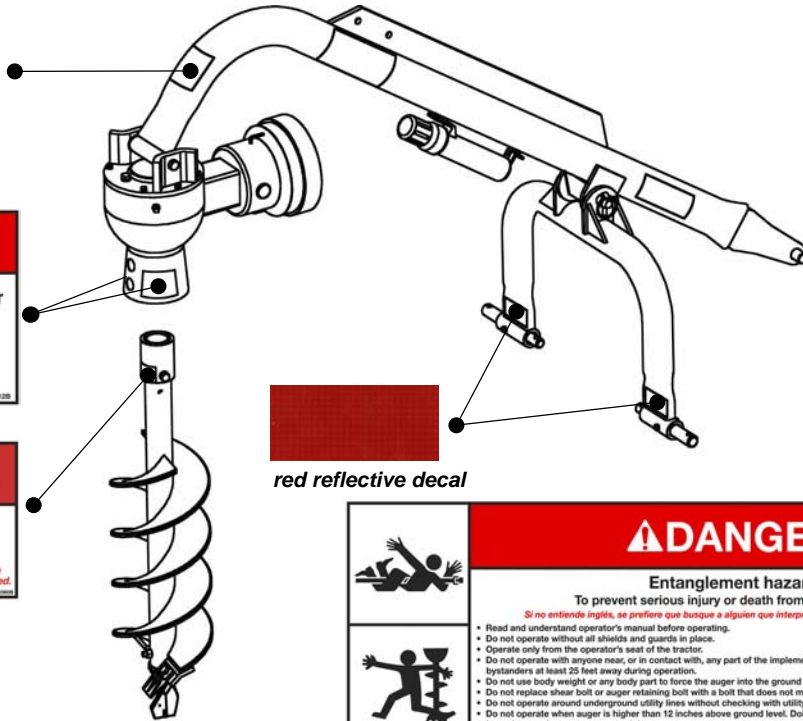

red reflective decal

⚠ DANGER

Entanglement hazard

To prevent serious injury or death from rotating parts:

Si no entiende inglés, se prefiere que busque a alguien que interprete las instrucciones para usted.

- Read and understand operator's manual before operating.
- Do not operate without all shields and guards in place.
- Operate only from the operator's seat of the tractor.
- Do not operate with anyone near, or in contact with, any part of the implement, PTO driveline, or auger. Keep bystanders at least 25 feet away during operation.
- Do not use body weight or any body part to force the auger into the ground or to position auger when auger is turning.
- Do not replace shear bolt or auger retaining bolt with a bolt that does not meet the manufacturer's specifications.
- Do not operate around underground utility lines without checking with utility authorities.
- Do not operate when auger is higher than 12 inches above ground level. Doing so may cause driveline to bind, resulting in equipment damage or operator injury.
- Stop auger rotation before maneuvering, relocating or transporting.

9506698



⚠ DANGER

Avoid injury from PTO

- Entanglement can cause serious injury or death.
- Keep driveline shields in place & in good condition.
- Keep hands, feet and clothing away.
- Operate only with 540 RPM.

9501298

right side

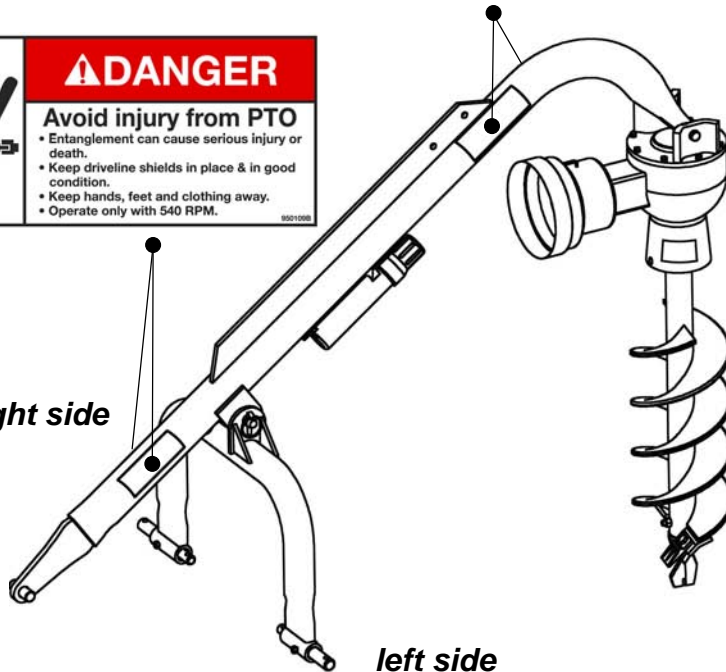

left side

3 - OPERATION

You have purchased a post hole digger that is constructed with heavy walled piping and a sturdy gearbox to ensure reliability whether it's for landscaping, farming or industrial purposes. The Mole series post hole diggers come in four sizes (100-512, 200-512, 300-512 & 400-512) and the augers range from 6" for small post holes, all the way up to 30" holes for tree root balls. The auger cutting teeth and point are easily replaceable. The driveline is fully shielded with shearpin safety. Available as an option are: A hydraulic down pressure kit (for models 200-512, 300-512 & 400-512) that allows for additional digging force in hard soil conditions; a hookup stand for easy and safe storage and a positioning handle that mounts on the gearbox of the digger to enable operator to easily position the auger point on the ground from tractor seat.

3.01- Operational Safety



CAUTION: Our post hole diggers are designed considering safety as the most important aspect. Unfortunately, human carelessness can override the safety features built into our machines. Injury prevention and work safety, aside from the features on our post hole diggers, are very much due to the responsible use of the equipment. It must always be operated prudently following with great care, the safety instructions laid out in this manual.



1. The use of this equipment is subject to certain hazards which cannot be prevented by mechanical means or product design. All operators of this equipment must read and understand this entire manual, paying particular attention to safety and operating instructions, prior to using.
2. Do not operate the tractor and implement when you are tired, sick or when using medication.
3. Keep all helpers and bystanders at least 25 feet from a post hole digger. Only properly trained people should operate this machine.
4. Before beginning operation, clear area of objects that could wrap around the auger or might be thrown. Contact local utility companies to make certain there are no bundled gas lines, electrical cables, etc., in the work area. Check for ditches, stumps, holes, or other obstacles that could cause the tractor to roll.
5. The majority of accidents involve entanglements on the driveline and on the auger. Accidents are most likely to occur with machines that are loaned or rented to someone who has not read the operator's manual and is not familiar with a post hole digger.

6. Always stop the tractor, set brake, shut off the tractor engine, remove the ignition key and allow moving parts to come to a complete stop before dismounting tractor. Never leave equipment unattended with the tractor running.
7. Keep hands, feet, hair, jewelry, and clothing away from all moving parts.
8. Do not allow riders on the digger or tractor at any time. There is no safe place for riders.
9. Do not allow anyone to stand behind, or to the side of, a rotating auger.
10. Before backing up, disengage the machine and look behind carefully.
11. Install and secure all guards and shields before starting or operating.
12. This post hole digger is designed for use only on tractors with 540 rpm power take off.
13. The rotating parts of this machine have been designed and tested for rugged use. However, they could fail upon impact with heavy, solid objects such as steel guard rails and concrete abutments. Such impact could cause the broken objects to be thrown outward at very high velocities. To reduce the possibility of property damage, serious injury, or even death, never allow auger teeth and point to contact such obstacles.
14. Frequently check auger teeth and point. They should be sharp, free of nicks and cracks and securely fastened.
15. Stop implement immediately upon striking an obstruction. Turn engine off, remove key, inspect and repair any damage before resuming operation.
16. Stay alert for holes, rocks and roots in the terrain and other hidden hazards. Keep away from drop-offs.
17. Do not operate digger on steep hillsides. When digging on uneven or hilly terrain, position the tractor with the post hole digger uphill. With the post hole digger downhill the tractor could tip when attempting to pull the auger from its hole.
18. When using a unit, a minimum 20% of tractor and equipment weight must be on tractor front wheels. Without this weight, tractor could tip over, causing personal injury or death. The weight may be attained with a front end loader, front wheel weights, ballast in tires or front tractor weights. When attaining a minimum 20% of tractor and equipment weight on the front wheels, you must not exceed the ROPS weight certification. Weigh the tractor and equipment. Do not guess or estimate!
19. Inspect the entire machine periodically². Look for loose fasteners, worn or broken parts, and leaky or loose fittings.
20. Use only the driveline supplied with the post hole digger. Do not use it if it is missing any shield or safety protection. Never replace the shear bolt or auger retaining bolt with any length other than what is specified in this manual. A longer or protruding fastener is more likely to grab loose clothing or gloves, which can result in serious injury or death.

3.02 - Set Up

Notice to dealer: Pre-delivery setup and service including lubrication is the responsibility of the authorized dealer. It is up to him to assure that the machine is in perfect condition and ready to be used. It is his responsibility to ensure that the

² See Chapter 4 - Maintenance.

customer is aware of all safety aspects and operational procedures for the post hole digger. He must also fill out the Pre-Delivery Checklist³ prior to delivering the machine.

3.03 - Pre-Operational Check

IMPORTANT: Check each of the following, carefully, prior to engaging the equipment:

1. Thoroughly read and understand your operator's manual.
2. The oil in the gearbox.
3. The driveline cross and bearings have been greased.
4. No wrappings or foreign objects are around the auger or driveline.
5. All hardware is tight⁴.
6. The tractor, to ensure correct direction of PTO and rpm speed.
7. All safety shields and guards are in place and tightly attached.
8. Clear area of objects that could wrap around the auger or might be thrown.
9. Contact local utility companies to make certain there are no bundled gas lines, electrical cables, etc., in the work area.
10. Check for ditches, stumps, holes, or other obstacles that could cause the tractor to roll.
11. Lay out and mark where you want to dig your holes.
12. **All** persons should be at least twenty-five feet (25') away. Clear the area of helpers, bystanders, especially children.
13. Do not allow anyone to stand behind or to the side of a rotating auger.
14. To dig properly, your digger must be able to raise or lower through the highest and lowest points of your lift arm travel without binding against the tractor frame. Check carefully **before** attaching the auger. If it does bind, adjust the tractor 3-point linkage so that all movement is free.



DANGER: Stay clear of rotating driveline and auger. Entanglement in rotating driveline and/or auger can cause serious injury or death. Disengage PTO, engage parking brake or place transmission in "Park", shut off the tractor and remove the key before working around hitch, attaching or detaching driveline, making adjustments, servicing or cleaning the machine.

3.04 - Assembly and Attaching to the Tractor

Following you will find the assembly instructions for your post hole digger. Please read this manual thoroughly before assembling the post hole digger. If you have any questions regarding the proper assembly or operation of this digger please contact your dealer or the Company.

³ See Chapter 7 - Pre-Delivery Checklist.

⁴ Refer to Table 3 - Torque Specifications, page 30.



CAUTION: Stand clear of bands when cutting as they could be under sufficient tension to cause them to fly loose. Take care in removing bands and wire, they often have extremely sharp edges and cut very easily.



WARNING: Personal protection equipment including hard hat, safety glasses, safety shoes, and gloves are recommended during installation, operation, adjustment and maintenance of the digger and auger. Do not allow long hair, loose fitting clothing, or jewelry to be around moving parts.

Below is a list of the items included in shipment of the post hole digger:	
1 Boom complete with:	1 Manual holder containing operator's & parts manual
1 Yoke complete with:	1 Hitch pin 2 Lynch pin
1 Gearbox complete with:	1 7/8" hanger pin 2 Cotter pins 1 Gearbox guard 1 Auger guard
1 PTO Shaft	
1 Hardware bag attached to gearbox hanger pin complete with:	1 Set screw with hex nut 1 3/8"x3" grade 2 shear bolt (for Mole 200, 300 & 400) or; 1/4"x2.5" grade 2 shear bolt (for Mole 100) 1 3/8" elastic stop nut (for Mole 200, 300 & 400) or; 1/4" elastic stop nut (for Mole 100) 2 Bolts HH M12-1.75x90 2 Nuts HH M12-1.75 2 Lock washers Ø12
Ensure you have all components before you begin assembly.	

To assemble the frame of the post hole digger proceed as follows (see fig. 3):

1. Lay out all parts to be assembled.
2. Attach gearbox to digger boom by using 7/8" hanger pin and cotter pins.
3. Connect digger boom to top link hitch of tractor using tractor pin and retaining pin.
Note: The post hole diggers 200-512, 300-512 & 400-512 come with a reduction bushing to be used on category 1 tractors.
4. Attach digger yoke to the boom assembly by using the hitch pin and lynch pins provided. Position yoke so that the red reflecting decals are visible from the rear of the tractor. Then connect digger yoke to lower lift links of tractor.
5. Connect sway bars or adjust sway links to retain digger side to side.



DANGER: Use only the driveline supplied with the post hole digger. Do not use it if it is missing any shield or safety protection. Never replace the shear bolt or auger retaining bolt with any length other than what is specified in this manual. A longer or protruding fastener is more likely to grab loose clothing or gloves, which can result in serious injury or death.



CAUTION: This machine is equipped with a shear bolt for the protection of the PTO and gearbox. Never replace the shear bolt with anything harder than a grade 2 bolt. All warranties will be void if a bolt harder than a grade 2 is used.

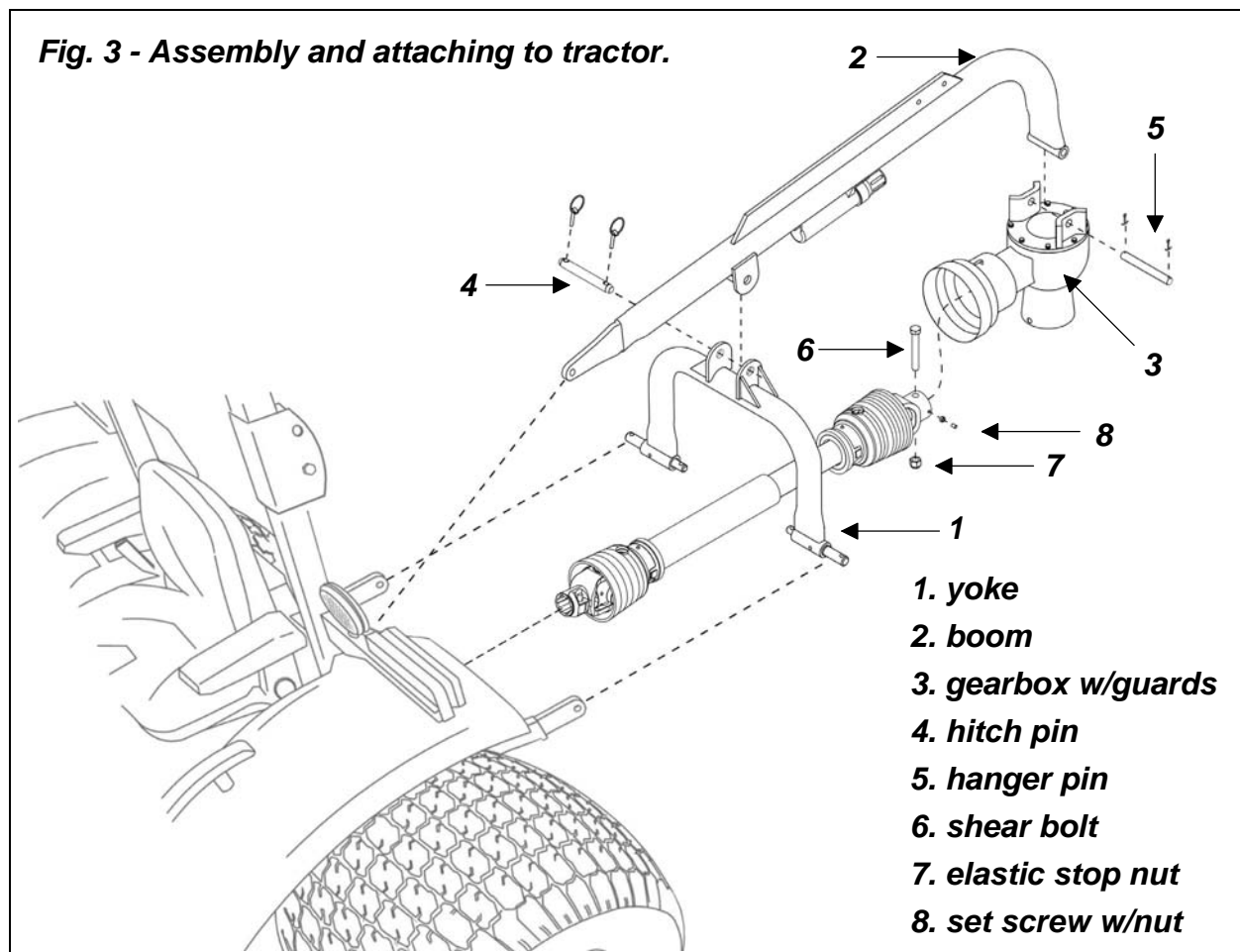

To install the driveline proceed as follows:

1. Use tractor's hydraulic lift to raise boom. Separate the 2 driveline halves. Attach outer driveline yoke to tractor PTO by pushing in the quick detachment pin and sliding drive shaft onto tractor. Attach inner driveline yoke to post hole digger

gearbox by using the 3/8"x3" grade 2 shear bolt (on the Mole 200, 300, and 400) or the 1/4"x2.5" grade 2 shear bolt (on the Mole 100) and elastic stop nut.

2. Raise and lower digger (**without the auger attached**) with the tractor's 3 point hitch to ensure the driveline has at least 2" from bottoming out in its shortest working position and has the minimum 6" overlap in its longest working position. Refer to **Section 4.03⁵** of this manual, if it is determined that the driveline is too long and needs to be shortened. Contact your local dealer if it is determined that the driveline is too short for your tractor. If the driveline is of the correct length proceed to step 3 below.
3. Apply multi-purpose grease to the inside of the outer driveline shaft and reassemble the two shafts.
4. Note: The driveline requires the use of a safety set screw (**see #8, fig. 3**) to prevent it from coming off the gearbox in the event that the shear bolt is sheared. Turn safety set screw all the way in the PTO shaft and into the groove of the input shaft of the gearbox. Back out set screw no more than 1/4 turn and secure with hex nut.
5. The driveline should now be moved back and forth to ensure that both ends are secured to the tractor and the post hole digger gearbox.
6. Install both driveline safety chains. One should be hooked in a hole on the outer driveline yoke shield and to the tractor to restrict outer shield rotation. The second one should be hooked in a hole on the inner driveline yoke shield and to the post hole digger to restrict inner shield rotation.

To install the auger proceed as follows (see fig. 4):

1. Position auger under the post hole digger gearbox.
2. Remove plastic caps on gearbox guard.
3. Attach auger to gearbox by using two bolts M12x90, lock washers and hex nuts. Torque appropriately.
4. Reinstall both caps on gearbox guard.
5. After completing assembly, thoroughly inspect the machine to be sure that all hardware has been thoroughly tightened and lubricated and check gearbox oil level.



DANGER: Failure to ensure a secure coupling of the implement to the tractor can cause injury and damage to the implement or tractor.

Only use this implement with tractors in the correct power range⁶. **Never use this machine with tractors over the maximum recommended HP.**



CAUTION: Check the tractor PTO rpm to ensure it is set at 540 and turns clockwise.

⁵ See Section 4.03 - Driveline, for instructions on how to determine correct driveline length and procedures for shortening the driveline.

⁶ See Table 1, Technical Features, page 29.



CAUTION: Always ensure that the tractor tire pressure is correct according to the tractor operator's manual.

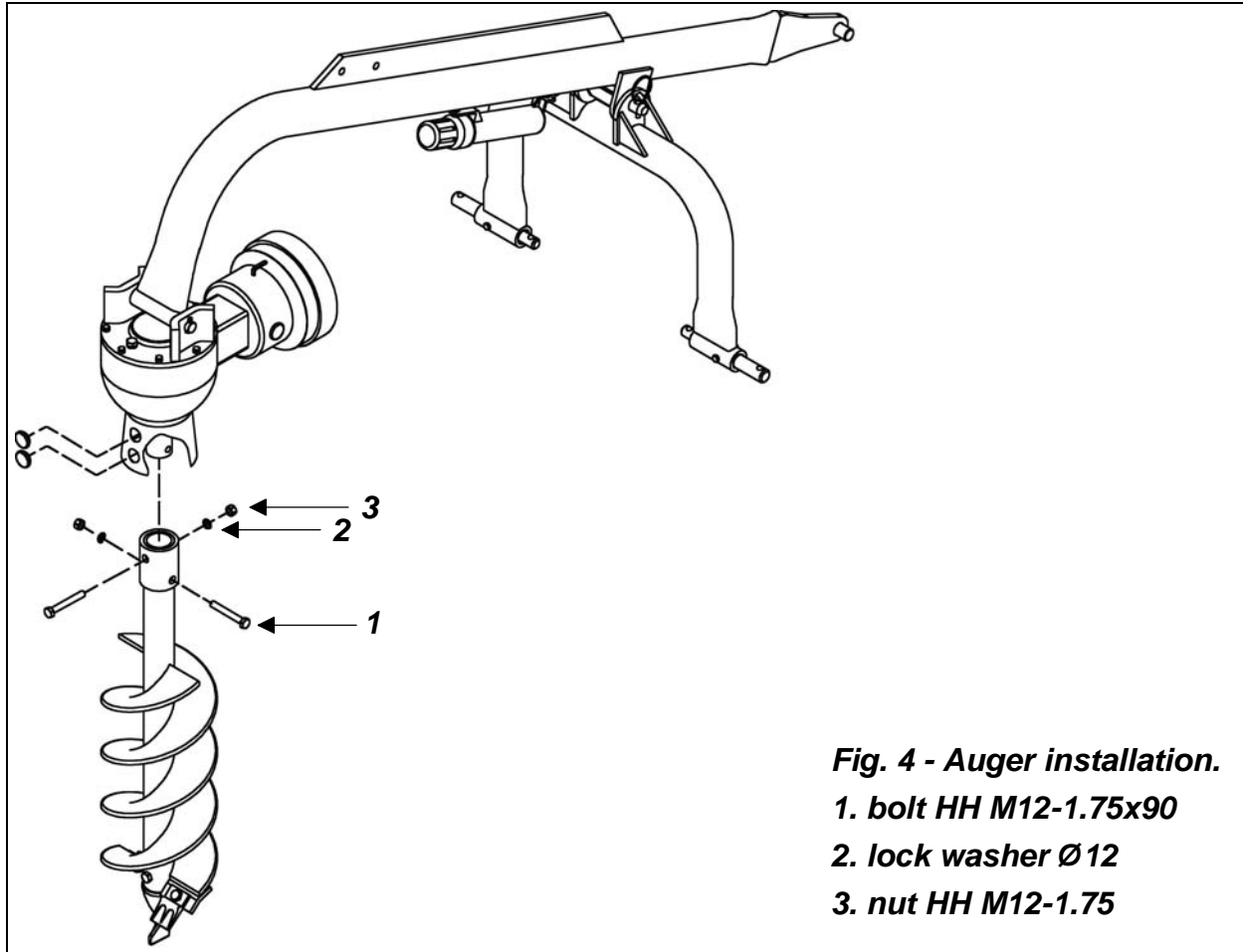

Fig. 4 - Auger installation.

1. bolt HH M12-1.75x90

2. lock washer Ø12

3. nut HH M12-1.75

3.05 - Start Up

It is essential that everyone involved in the assembly, operation, transport, maintenance, and storage of the equipment be aware, concerned, prudent, and properly trained in safety.



DANGER: This post hole digger was designed for one-man operation from the tractor seat. It is the responsibility of the operator to see that no one is within twenty-five feet (25') of the digger when it is started.



DANGER: Stand clear of auger and driveline when in operation. Failure to do so could result in serious injury or death.



WARNING: Remain on the tractor seat while operating the post hole digger. Assisting the machine by hand can result in serious injury or death.



WARNING: Never locate auger by putting hands on auger, gearbox, or boom assembly when there is any sign of rotation on the driveline or auger or if the tractor is running.



CAUTION: Never engage PTO when auger point is more than 1' above the ground.

Follow the below procedures to start working:

1. The auger needs to work in a vertical position. To adjust the auger to a vertical position, raise the auger point off the ground and turn the leveling crank on the lifting link of the tractor until the auger is vertical. With the PTO disengaged, slowly lower the auger until the auger point just engages the ground. Move the tractor slowly forward or backward (as needed) until the auger is vertical with respect to the ground.
2. Set tractor brakes.
3. Take tractor out of gear.
4. With the auger point lowered to the ground, set the engine speed to idle, then engage the PTO. Make sure the auger point is on the ground before engaging the PTO.
5. Increase the speed as required so dirt is conveyed from the hole. Refer to the tractor's operator's manual for suggestions on PTO speed.
6. Under no circumstances should the PTO be run in excess of 540 rpm.
7. In many types of soil, it may be necessary to hold back against the auger screw suction by moving the hydraulic control lever to "HOLD" or "RAISE" position to keep the auger from screwing into the ground.
8. **Never** use body weight to help the auger penetrate the ground. When the ground is too tough to penetrate with your cutting edges and point, replace them and try again. These are replaceable parts and must be in good condition to penetrate.
9. If you have difficulty penetrating hard ground, refer to the Troubleshooting section of this manual.
10. When the auger has been lowered a foot or so into the ground, raise the auger almost out of the hole to clear the dirt, then drill deeper and raise the auger again. Repeat this procedure until the desired hole depth is reached.

11. Once the auger is digging a hole, the tractor cannot be moved. Make sure brake is set securely. If the tractor does move while the auger is in a hole, damage to the gearbox or auger can result (not covered by warranty).
12. Be sure auger is completely retracted from the hole before attempting to move the tractor.
13. Do not shovel dirt away from a rotating auger as the shovel can be caught and thrown by the auger.
14. Leave the power take off disengaged when traveling between holes.

Keep safety shields in place at all times.

3.06 - Transport



CAUTION: Do not tow tractor and implement behind other vehicles. Use a properly equipped trailer with heavy tie-downs for towing operations.

Before transporting:

1. Always select a safe ground speed that is appropriate for the terrain.
2. Beware of traffic on public roads. Install a SMV (Slow Moving Vehicle) sign when traveling on roads or streets. Make sure the SMV sign on the tractor and other reflectors are clearly visible. If the view of the SMV sign is being blocked by the post hole digger, a bracket is available from the factory that allows you to mount the SMV sign on the implement itself. Comply with all federal, state and local laws.
3. Reduce ground speed when turning and take care that the implement does not strike obstacles such as trees, fences or buildings.

3.07 - Optional Down Pressure Kit

The hydraulic down pressure kit allows for additional digging force in hard soil conditions. The kit consists of a cylinder that attaches to the post hole digger by the use of mounting plates. It operates using the tractor hydraulic system and it provides between 300 and 500 lb. of additional down pressure depending on mounting configuration.



WARNING: High pressure hydraulic oil leaks can penetrate skin resulting in injury, gangrene or death. Be sure to relieve any hydraulic oil pressure before disconnecting any lines or pipes between post hole digger and tractor hydraulic system. Check for oil leaks using a cardboard, never use hands.

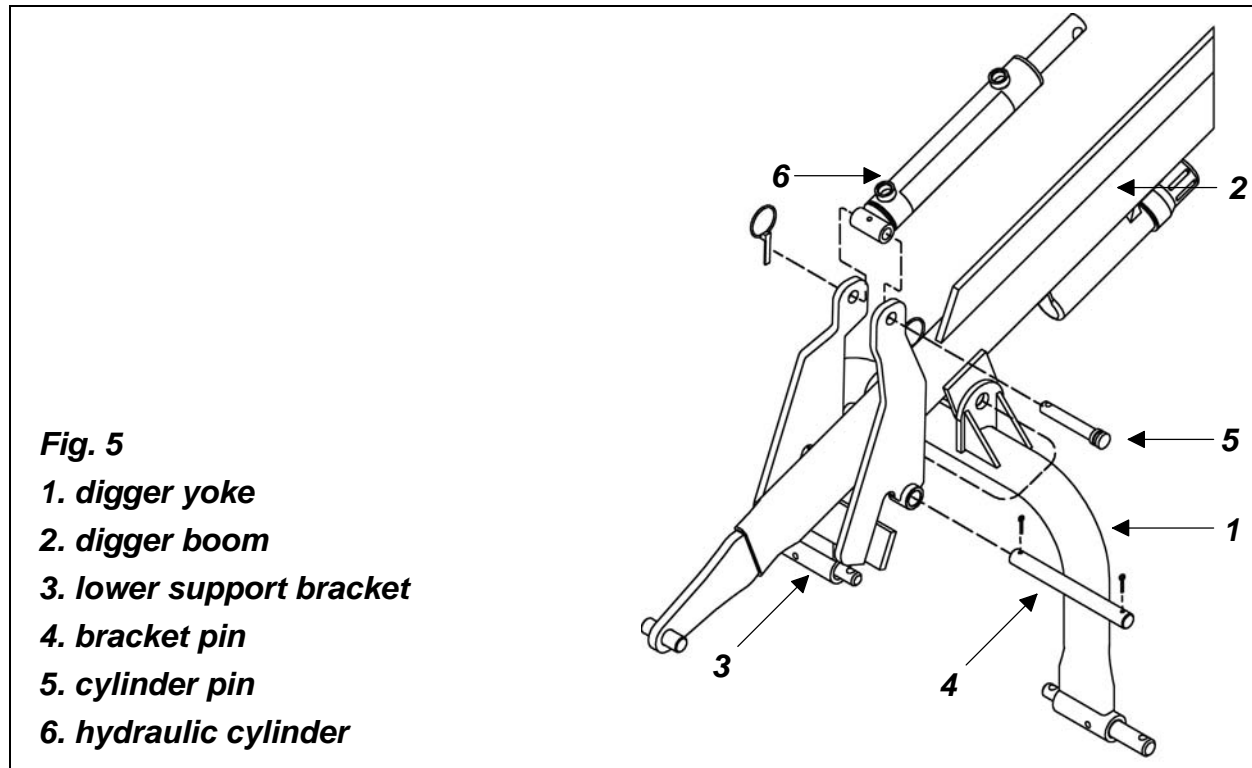

Fig. 5

1. digger yoke
2. digger boom
3. lower support bracket
4. bracket pin
5. cylinder pin
6. hydraulic cylinder

IMPORTANT: Serious damage can occur to post hole digger and down pressure kit if tractor hydraulics does not have float capabilities.

To assemble the down pressure kit proceed as follows:

1. Lower post hole digger until auger point is resting on the ground.
2. Remove pin that connects the yoke to digger boom.
3. Assemble lower support bracket (**see #3, fig. 5**) to digger boom and yoke by using the new pin (**see #4, fig. 5**) that is pre-installed on the bracket. Insert both cotter pins after mounting pin.
4. Assemble mounting plates to digger boom (**see fig. 6**) using hex bolts 1/2"x1.75", lock washers 1/2" and hex nuts 1/2" provided.
5. Mount the hydraulic cylinder (**see #6, fig. 5**) on top of lower support bracket using the cylinder pin 3/4"x3.88" (**see #5, fig. 5**) and lynch pin. Mount non-action end of the cylinder on the lower support bracket.
6. Mount the other end of the hydraulic cylinder on mounting plates (**see #1, fig. 6**) using cylinder pin 3/4"x3" (**see #2, fig. 6**) and hairpin cotter provided.
7. Hydraulic hoses come pre-assembled to the pressure relief valve and the shuttle valve, connect assembly to the cylinder (**see fig. 7**).
8. Install a return line (not provided with the kit) to tee fitting (**see fig. 7**). Use teflon tape to seal pipe threads.
9. Connect pressure line to tractor hydraulic outlet and the return line to reservoir.

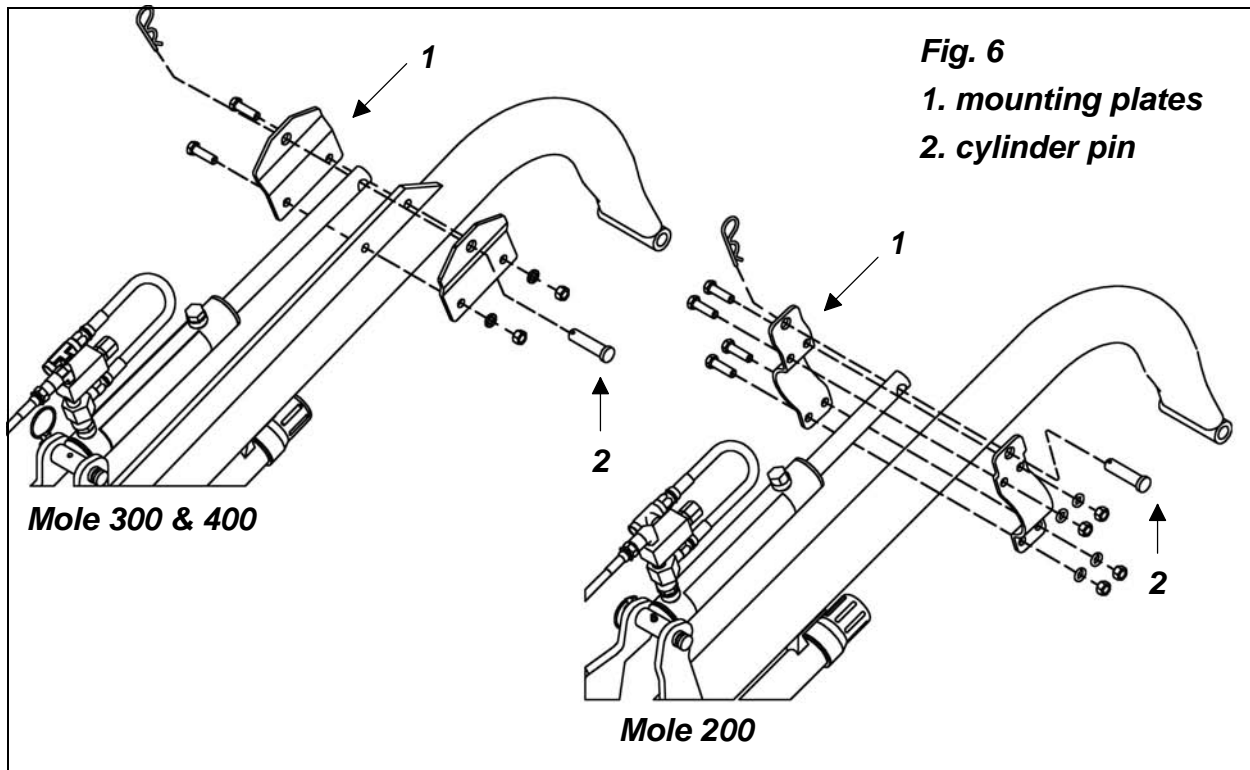

IMPORTANT: Do not connect return line to tractor remote outlet. Damage will occur to frame if not properly hooked up to reservoir.

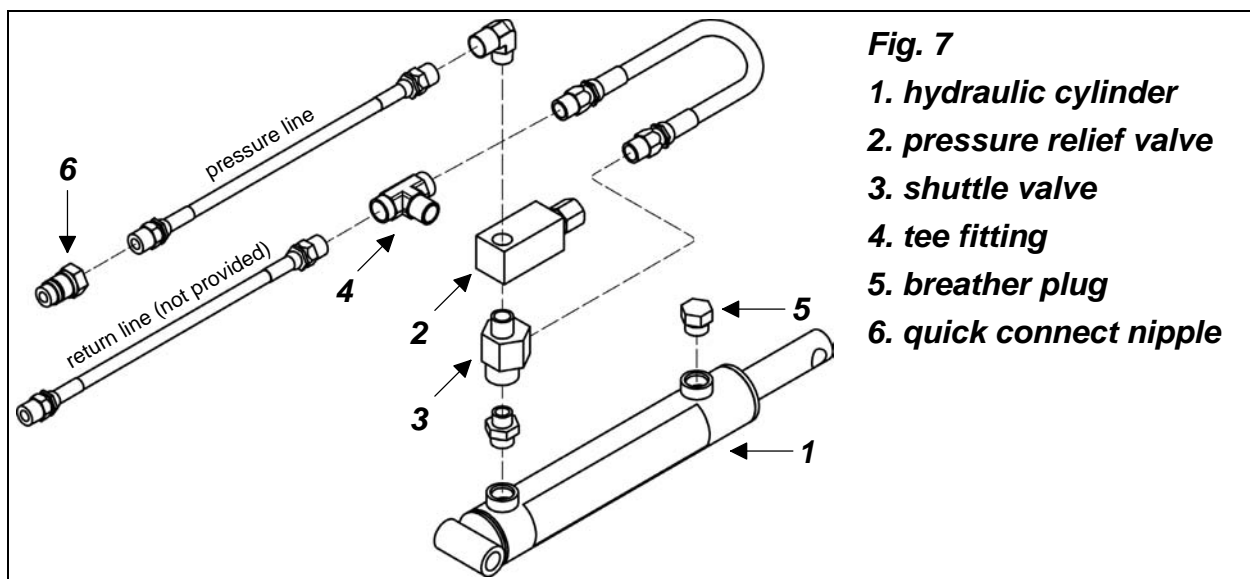

CAUTION: Hydraulic pressure relief valve is preset at 1500 psi and should not be changed. Increasing the pressure can result in damage to the equipment.

3.08 - Optional Hookup Stand

The hookup stand can be used with all Mole models. It is ideal for storing the post hole digger safely and will prolong implement's life by keeping it off the ground. The foldable hookup stand will also allow for easy mounting and dismounting of the post hole digger to the tractor. The hookup stand has several adjusting height options to accommodate your needs.

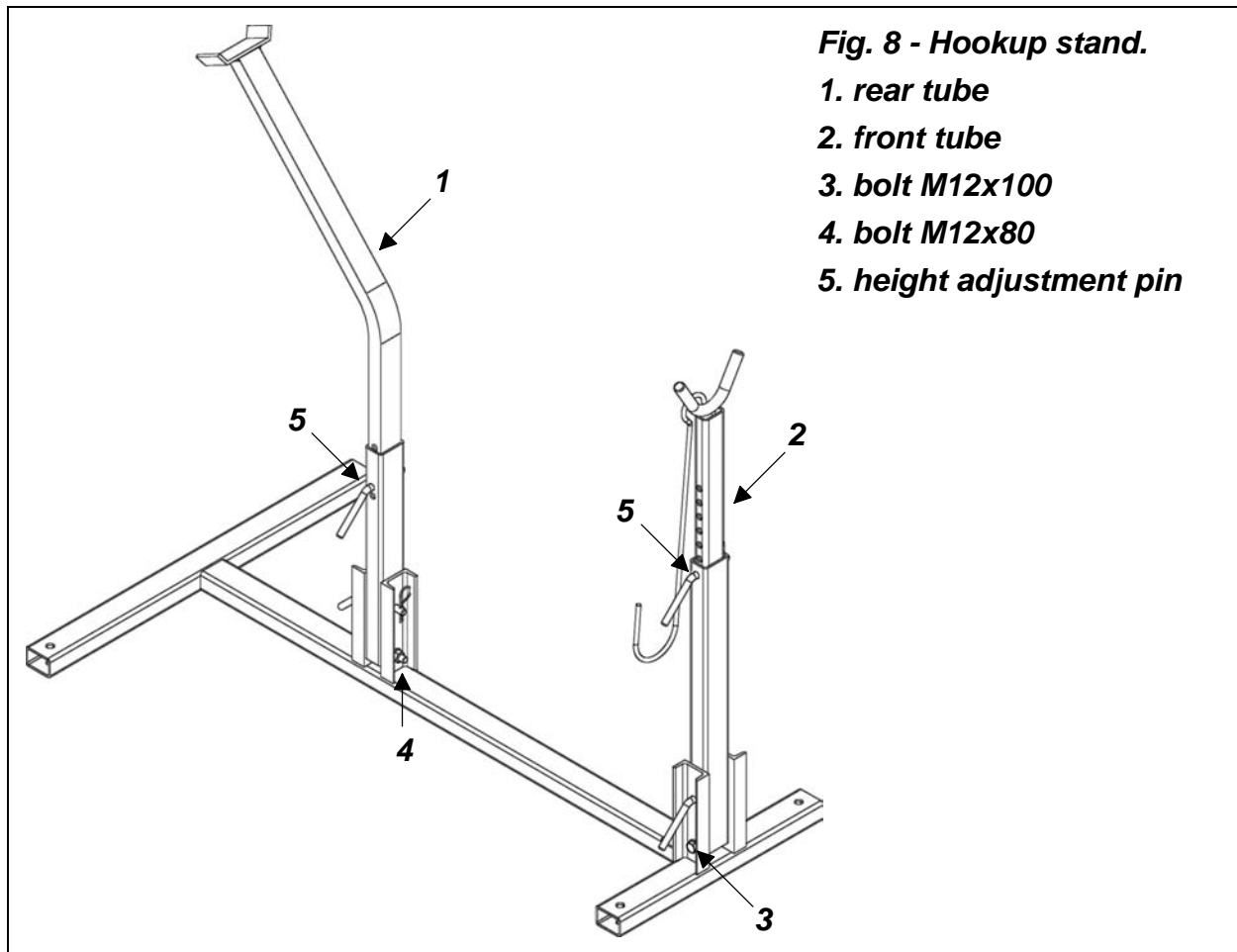

To assemble the hookup stand proceed as follows (**see fig. 8**):

1. Place stand base on a level surface.
2. Insert rear (gearbox side) and front (boom side) tubes into mounting bracket on stand base and secure bottom hole of both tubes with the bolt (use M12x100 on front tube and M12x80 on rear tube), two flat washers (one per each side of mounting bracket) and tighten with locknut.
3. Insert a pin in the top hole of both mounting brackets making sure longer pin is used on the 'Y' shaped bracket and secure with cotter pins.
4. Once the stand is located in a permanent position, secure it by placing stakes or screws in all corners.



DANGER: Stop engine, lock parking brake and remove key before dismounting tractor.

The stand is foldable in order to help position the post hole digger. Removing the bottom pins on each mounting bracket will enable tubes to fold down. Once post hole digger is properly aligned on stand base, shut tractor off and lock parking brakes before dismounting tractor, raise front and rear tubes back into a vertical position and re-secure with pins and cotter pins previously removed, and carefully lower implement on stand. Disconnect 3 point hitch and completely unhook all attachments before driving away from stand.

IMPORTANT: For stability reasons the stand has been designed with holes in all ends of the base. The end user is responsible for providing stakes to insert into the ground through the holes and for selecting a terrain that is suitable to securely anchor the stand. The stakes need to be at least 12" in length to prevent tipping of the unit.

3.09 - Optional Positioning Handle

The positioning handle (**see fig. 9**) mounts on the post hole digger gearbox and allows to position accurately auger point on the ground from operator's seat. Raise handle to move auger point towards the tractor or lower handle to move auger tip away from the tractor. This option is available for all models.

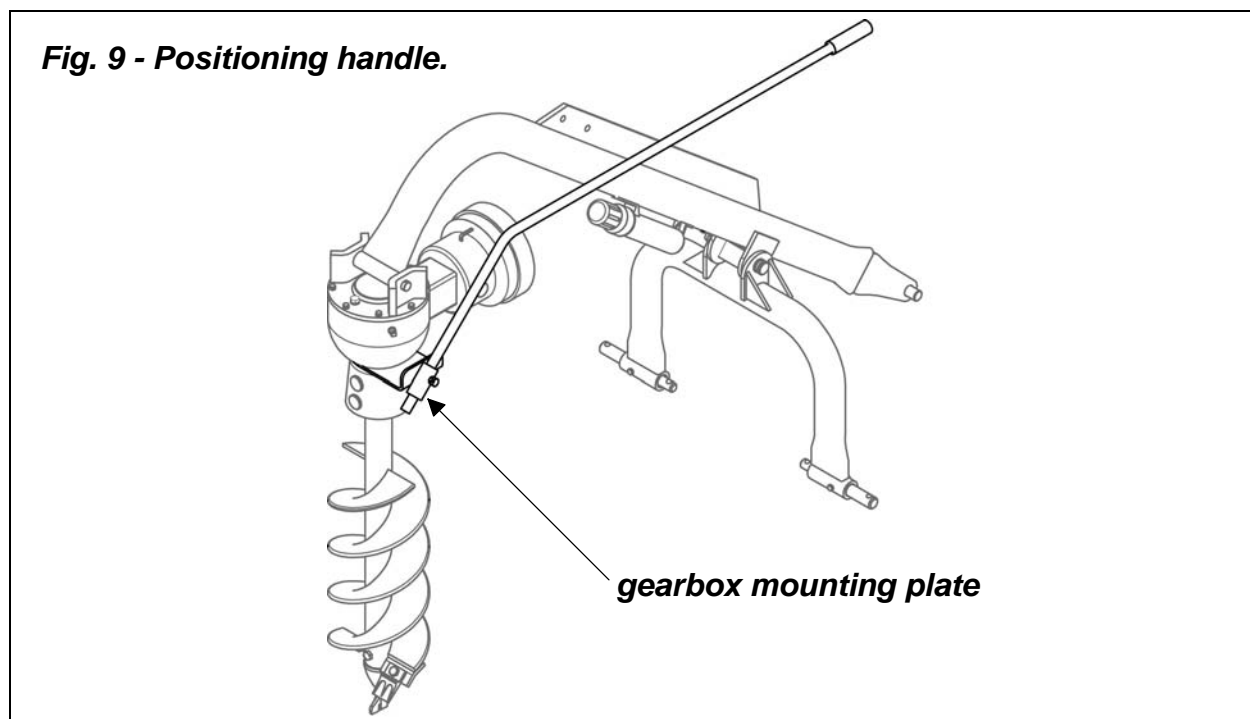

4 - MAINTENANCE



DANGER: Stop engine, lock parking brake and remove key before performing any service or maintenance.

Never rely on the tractor lift system. Install blocks or stands⁷ under the post hole digger to prevent it from falling.

Always use personal protection devices, such as glasses or gloves when performing maintenance.

Keep fingers out of slots to prevent injury.

4.01 - Maintenance Safety



1. Good maintenance is your responsibility.
2. Keep service area clean and dry. Be sure electrical outlets and tools are properly grounded. Use adequate light for the job at hand.
3. Make sure there is plenty of ventilation. Never operate the engine of the towing vehicle in a closed building. The exhaust fumes may cause asphyxiation.
4. Make no repair or adjustments with the tractor engine running. Before working on the machine, disengage the PTO, shut off the engine, set the brakes, and remove the ignition key.
5. Be certain all moving parts on attachment have come to a complete stop before attempting to perform maintenance.
6. Never work under equipment unless it is blocked securely.
7. Always use personal protection devices such as eye, hand and hearing protectors, when performing any service or maintenance.
8. Periodically tighten all bolts, nuts and screws and check that all cotter pins are properly installed to ensure unit is in a safe condition.
9. When completing a maintenance or service function, make sure all safety shields and devices are installed before placing unit in service.
10. After servicing, be sure all tools, parts and service equipment are removed.
11. Never replace hex bolts with less than grade five bolts unless otherwise specified, i.e. shear bolts⁸.
12. Where replacement parts are necessary for periodic maintenance and servicing, genuine replacement parts must be used to restore your equipment to original specifications. The company will not claim responsibility for use of unapproved parts and/or accessories and other damages as a result of their use.

⁷ An optional hookup stand to securely support the post hole digger is available upon request. See Section 3.08.

⁸ Refer to Table 3 - Torque Specifications, page 30.

13. Unauthorized modifications to the machine may impair the function and/or safety of the machine and reduce its life. If equipment has been altered in any way from original design, the manufacturer does not accept any liability for injury or warranty.

4.02 - Service

The chart below gives the frequency of lubrication in hours, based on normal operating conditions. Severe or unusual conditions may require more frequent lubrication. Use a good quality SAE multipurpose type grease for all locations shown. Be sure to clean fittings thoroughly before using grease gun.

Use 90 wt. gear oil in gearbox. Replace the gearbox oil after the first 200 hours of use.

During operation, listen for abnormal sounds which might indicate loose parts, damaged bearings, or other damage.

Replace immediately any damaged or missing safety shields.

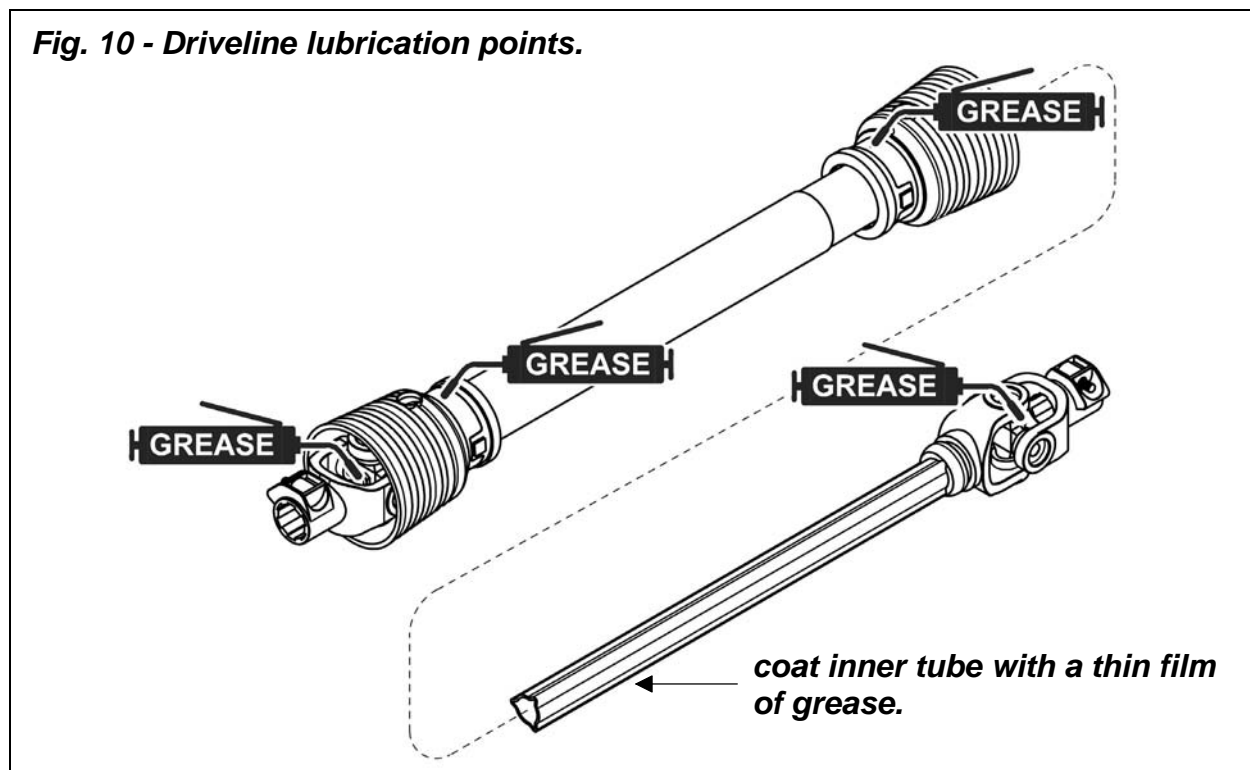

Every 8 hours:

1. Clean foreign material from post hole digger.
2. Inspect the auger's cutting teeth and auger point for excessive wear. The amount of wear will depend on the soil type and soil condition.
3. Clean the auger teeth and point to insure a longer machine life.

4. **Lubricate the driveline (see fig. 10):** Apply two or three shots of grease to the driveline cross and bearings and to the inner and outer locking rings. (See the driveline manufacturer operator's manual for further information on the driveline.)
5. Maintain driveline shear bolt at all times. A faulty shear bolt can inflict extreme damage to the implement. A grade 2 shear bolt that measures 1/4"x2.5" should always be used on model 100-512. A grade 2 shear bolt that measures 3/8"x3" should always be used on models 200-512, 300-512 and 400-512. **Never replace the shear bolt with any bolt longer or of a harder grade.**
6. **Gearbox oil level (see fig. 11):** Check the oil by removing the oil plug on the back side of the gearbox casing. The oil should be up to the bottom threads of the oil level hole. If needed remove the fill plug and add SAE 90 wt. gear oil.

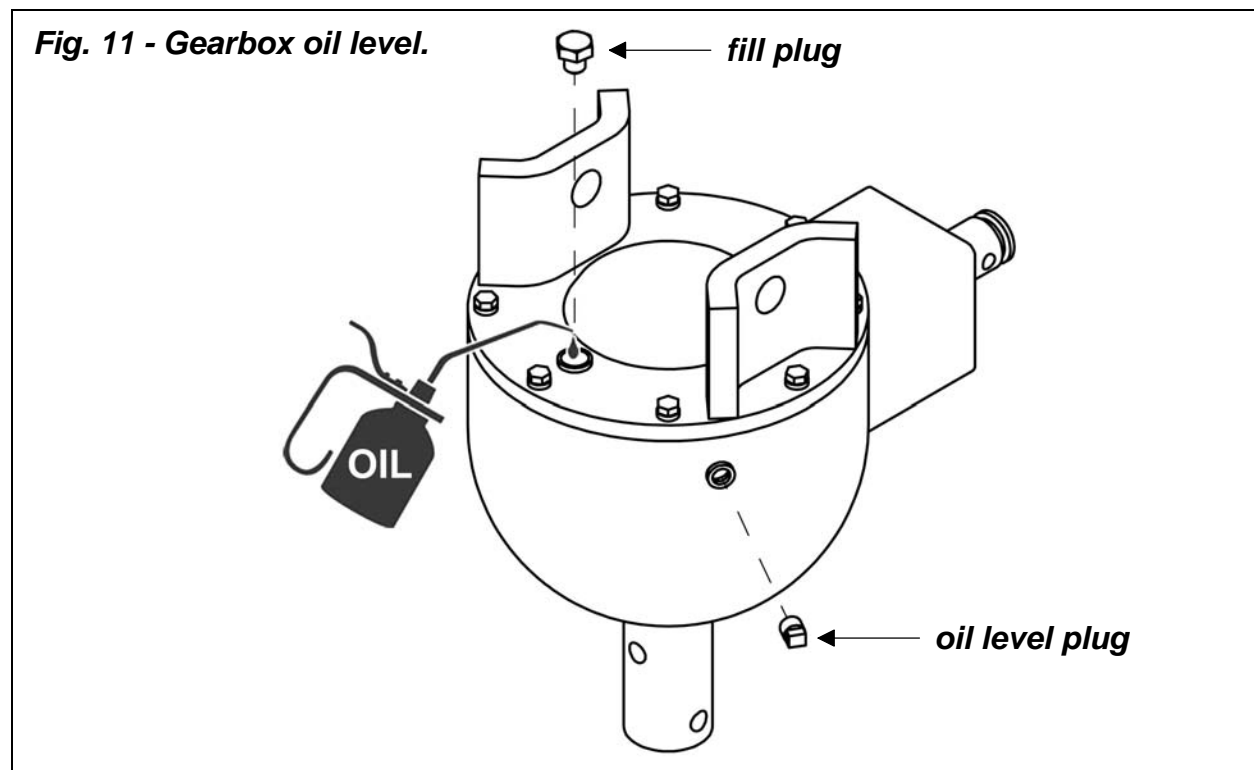

Every 25 hours:

1. **Check hardware tightness;** vibrations can loosen bolts. Check tightness of the hardware periodically, using **Table 3** as a guide⁹.
2. Check for loose, worn or damaged teeth and point.

⁹ Refer to Table 3, Torque Specifications, page 30.

4.03 - Driveline



DANGER: Use only the driveline supplied with the post hole digger. Do not use it if it is missing any shield or safety protection. Never replace the shear bolt or auger retaining bolt with any length other than what is specified in this manual. A longer or protruding fastener is more likely to grab loose clothing or gloves, which can result in serious injury or death. Carefully read and file away the driveline operator's manual supplied by the manufacturer. The following does not substitute the information found in the driveline manual.



CAUTION: This machine is equipped with a shear bolt for the protection of the PTO and gearbox. Never replace the shear bolt with anything harder than a grade 2 bolt. All warranties will be void if a bolt harder than a grade 2 is used.

IMPORTANT: Always check driveline length during initial setup and when connecting to a different tractor.

In the collapsed position the driveline should be approximately 2" from bottoming out to prevent possible damage to the tractor or implement. When the driveline is in the maximum extended position, the ideal minimum overlap of the two halves should be approximately 6" (see fig. 12).

Fig. 12

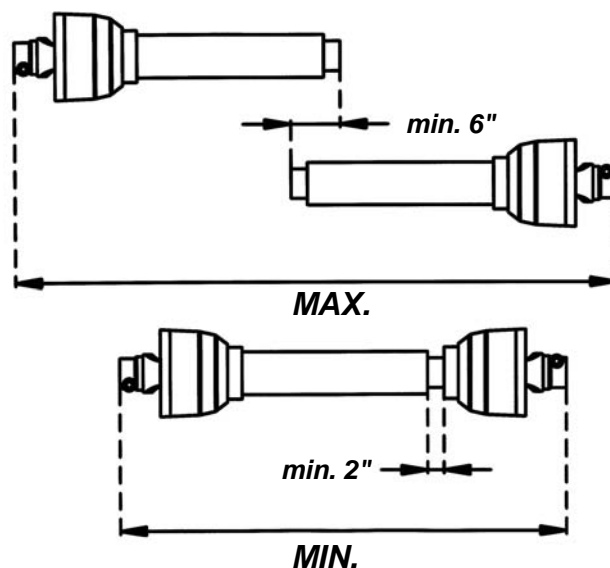

To determine if the driveline is the correct length for your tractor proceed as follows:

1. Separate the two driveline halves. Connect outer driveline yoke to tractor PTO and inner driveline yoke to post hole digger gearbox.
2. Raise the implement (**without the auger attached**) with the 3 point hitch to find **highest** working position. Hold half shafts side by side. At that point the driveline should have at least 6" of overlap. If not, do not use and contact your dealer.
3. Then lower the implement to the **lowest** working position. Hold the half shafts side by side. At that point the driveline should be at least 2" from bottoming out. If not, mark desired lengths on both shafts. Remove drivelines from implement and tractor.
4. Shorten both metal drive tubes the same amount.
5. Cut both guard tubes 1.5" shorter than the metal drive tubes.
6. De-burr and clean filings from drive tubes and apply grease to outside of inner metal drive tube.
7. Reassemble the driveline halves and connect to tractor and implement.
8. Install both driveline safety chains. One should be hooked in a hole on the outer driveline yoke shield and to the tractor to restrict outer shield rotation. The second one should be hooked in a hole on the inner driveline yoke shield and to the post hole digger to restrict inner shield rotation.
9. Raise and lower implement again to be sure driveline does not bottom out in its shortest position and has a minimum overlap of 6" in the longest position.



CAUTION: Always work with the driveline as straight as possible. This will prolong its life and that of its components. It is advised not to work at an angle greater than 15 degrees.

TABLE 1 - POST HOLE DIGGERS - TECHNICAL FEATURES







Series Mole, for tractors up to 90 HP, PTO 540 rpm, 3 point hitch cat. 1*							
Model	HP	Weight lb.	Boom OD	Yoke OD	Auger rpm	Gear ratio	Driveline 1 3/8"
100-512	15-25	112	2 7/8"	2 3/8"	180	3:1	ASAE 2 nd cat.
200-512	18-40	200	3 1/2"	2 7/8"	180	3:1	ASAE 3 rd cat.
300-512	18-50	230	3 1/2"	2 7/8"	154	3.5:1	ASAE 3 rd cat.
400-512	18-90	260	3 1/2"	2 7/8"	135	4:1	ASAE 3 rd cat.

* Cat. 1 & 2 on the Mole 300 and 400.
Note: Both the Mole 300 and 400 have reinforced booms and yokes.

TABLE 2 - AUGERS - TECHNICAL FEATURES

Series 531 Augers						
Model	Weight lb.	Size	Length	Flighting type	Flighting thickness	Recommended for models
106-531	24	6"	36"	single	3/16"	100-512
109-531	42	9"	36"	double	3/16"	100-512
112-531	52	12"	36"	double	3/16"	100-512
206-531	32	6"	48"	single	3/16"	200-512, 300-512 & 400-512
209-531	55	9"	48"	double	3/16"	200-512, 300-512 & 400-512
212-531	75	12"	48"	double	3/16"	200-512, 300-512 & 400-512
218-531	80	18"	48"	double	1/4"	300-512 & 400-512
224-531	105	24"	48"	double	1/4"	300-512 & 400-512
230-531	213	30"	44"	double	5/16"	300-512 & 400-512

TABLE 3 - TORQUE SPECIFICATIONS

Metric (ISO) treaded bolts head marking							Inch (SAE) treaded bolts head marking								
	Class 5.8	Class 8.8	Class 10.9	Grade 2	Grade 5	Grade 8									
Bolt size mm	Thread mm	N.m	ft-lb	N.m	ft-lb	N.m	ft-lb	Bolt size inch	Thread inchi tpi	N.m	ft-lb	N.m	ft-lb	N.m	ft-lb
M5	0.8	4	3	6	4	9	7	1/4"	20	7	5	11	8	16	12
M6	1	6	4	10	7	15	11	1/4"	28	8	6	13	10	19	14
M8	1.25	16	12	25	18	36	27	5/16"	18	15	11	24	17	33	25
M8	1	17	13	26	19	38	28	5/16"	24	17	13	26	19	37	27
M10	1.5	31	23	48	35	71	52	3/8"	16	27	20	42	31	59	44
M10	1.25	33	24	51	38	75	55	3/8"	24	31	23	47	35	67	49
M10	1	35	26	53	39	78	58	7/16"	14	43	32	67	49	95	70
M12	1.75	54	40	84	62	123	91	7/16"	20	48	36	75	55	106	78
M12	1.5	56	41	87	64	128	94	1/2"	13	66	48	102	75	144	106
M12	1.25	59	44	90	66	133	98	1/2"	20	75	55	115	85	163	120
M14	2	84	62	133	98	195	144	9/16"	12	95	70	147	109	208	154
M14	1.5	94	69	142	105	209	154	9/16"	18	106	79	164	121	232	171
M16	2	131	97	206	152	302	223	5/8"	11	132	97	203	150	287	212
M16	1.5	141	104	218	161	320	236	5/8"	18	149	110	230	170	325	240
M18	2.5	181	133	295	218	421	310	3/4"	10	233	172	361	266	509	376
M18	2	196	145	311	229	443	327	3/4"	16	261	192	403	297	569	420
M18	1.5	203	150	327	241	465	343	7/8"	9	226	167	582	430	822	606
M20	2.5	256	189	415	306	592	437	7/8"	14	249	184	642	473	906	668
M20	1.5	288	212	454	335	646	476	1"	8	339	250	873	644	1232	909
M22	2.5	344	254	567	418	807	595	1"	12	371	273	955	704	1348	995
M22	1.5	381	281	613	452	873	644	1-1/8"	7	480	354	1077	794	1746	1288
M24	3	444	327	714	526	1017	750	1-1/8"	12	539	397	1208	891	1958	1445
M24	2	488	360	769	567	1095	808	1-1/4"	7	677	500	1519	1120	2463	1817
M27	3	656	484	1050	774	1496	1103	1-1/4"	12	750	553	1682	1241	2728	2012
M27	2	719	530	1119	825	1594	1176	1-3/8"	6	888	655	1992	1469	3230	2382
M30	3.5	906	668	1420	1047	2033	1499	1-3/8"	12	1011	746	2268	1673	3677	2712
M30	2	1000	738	1600	1180	2250	1659	1-1/2"	6	1179	869	2643	1949	4286	3161
M36	4	1534	1131	2482	1830	3535	2607	1-1/2"	12	1326	978	2974	2194	4823	3557

When using lock washers with nuts, increase torque values by 5%.

5 - REPAIR PROCEDURES



CAUTION: All repair procedures must be done by authorized dealerships. It is not recommended that untrained individuals perform any repair work. The following operations are detailed for qualified personnel only.

5.01 - Shear Bolt Replacement

To replace a broken shear bolt proceed as follows:

1. Remove plastic cap on gearbox guard.
2. Remove broken shear bolt.
3. Install a new shear bolt and nut. Use a 3/8"x3" grade 2 shear bolt (on the 200-512, 300-512, and 400-512) or a 1/4"x2.5" grade 2 shear bolt (on the 100-512).
4. Tighten shear bolt and nut.
5. Ensure that the safety set screw is properly installed on PTO shaft and into the groove of the input shaft of the gearbox.
6. Replace plastic cap on gearbox guard.



DANGER: Use only the driveline supplied with the post hole digger. Do not use it if it is missing any shield or safety protection. Never replace the shear bolt or auger retaining bolt with any length other than what is specified in this manual. A longer, or protruding, fastener is more likely to grab loose clothing or gloves, which can result in serious injury or death.



CAUTION: This machine is equipped with a shear bolt for the protection of the PTO and gearbox. Never replace the shear bolt with anything harder than a grade 2 bolt. All warranties will be void if a bolt harder than a grade 2 is used.

5.02 - Suggested Spare Parts

It is suggested that the following spare parts be kept on hand for the post hole digger at all times to prevent a minor problem from delaying work.

Description	Quantity
Auger point	1
Auger teeth	4
Shear bolt	3
Hanger pin	1

5.03 - Storage

After seasonal use it is important to perform the following for prolonged storage:

1. Wash the post hole digger and auger carefully.
2. Inspect the machine and replace worn or damaged parts.
3. Tighten all hardware.
4. Grease or oil all areas indicated under Maintenance¹⁰.
5. Touch up scratches by sanding the area and applying a light coat of primer and paint to prevent rust from forming.
6. Coat the auger with grease to prevent rust.
7. Cover the post hole digger and auger from the elements in order to have it in perfect condition for the start of the next season.
8. Do not permit children to play on or around the stored unit.
9. Make sure all parked machines are on a hard, level surface, and engage all safety devices.

Touch up paint available:	
Part #	Description
7300007	Primer, gray - aerosol spray can
7300008	Paint, Befco orange - aerosol spray can
7300010	Paint, Befco black - aerosol spray can

Note: The machine demolition operations should be carried out in compliance with all federal, state and local environment protection laws.

¹⁰ See Chapter 4 - Maintenance.

6 - TROUBLESHOOTING



WARNING: Be sure tractor engine is off, parking brake is locked, and key is removed before making any adjustments.

PROBLEM	POSSIBLE CAUSE	SOLUTION
Auger won't dig.	Dull or worn teeth. Dry or hard ground. Auger turning rapidly and bouncing around. Auger is being held by rocks and other interference. Shear bolt broken.	Replace teeth. Add water to location where hole is desired. Reduce engine speed and never operate above 540 rpm. Remove auger from hole and check auger. Replace shear bolt.
Auger won't dig deep enough.	Something may be interfering with the downward motion of the digger. Most likely the driveline may be too long.	Remove digger from hole and lower to the ground. The gearbox should be able to touch the ground. If not remove driveline and shorten. Always maintain a minimum of 6" overlap of the PTO shafts.
Auger screws itself into the ground.	The 3 point hitch was not lowered to the ground slow enough. Tractor is too small to handle digger. Faulty 3 point hitch on the tractor.	Remove from hole and begin again but lower the 3 point to the ground slowly. Use a larger tractor. Remove from hole and carefully remove the digger from the tractor Have the tractor serviced at your tractor dealership.
Drive shaft falls off gearbox when shear bolt breaks.	Set screw may be loose or missing off of drive shaft.	Check set screw and replace or tighten as needed.

7 - PRE-DELIVERY CHECKLIST

To the dealer: Inspect the machine thoroughly after assembly to assure it is functioning properly before delivering it to the customer. The following checklist is a reminder of points to cover. Check off each item as it is found satisfactory or after proper adjustment is made.

- Gearbox oil level.
- Guards and shield properly fastened.
- Lubrication of grease fittings.
- All hardware properly tightened.
- All decals properly located and readable (**see fig. 2**).
- Overall condition (touch up scratches, clean and polish).
- Test run, check for excessive vibrations or overheating of bearings.
- Operator's Manual.

Review the Operator's Manual with the customer. Explain the following:

- Warranty.
- Safe operation and service.
- Correct machine installation and operation.
- Daily and periodic lubrication, maintenance and inspections.
- Troubleshooting
- Operational procedures and storage.
- Parts and service.
- Remove and fill out the Pre-Delivery Checklist and Warranty Registration form.
- Give customer the Operator's Manual and encourage the customer to read the manual carefully.

IMPORTANT: Warranty is not valid unless Pre-Delivery Checklist and Warranty Registration form in Operator's Manual is completed in detail and mailed to the Company.

Model Number: _____ Serial Number: _____

Delivery Date: _____ Dealer's Signature: _____

8 - WARRANTY

BEFCO's responsibility will be limited to substitution of the acknowledged defective merchandise to the same place of delivery as the previous one was supplied.

1. LIMITED WARRANTY

BEFCO, Inc. herein referred to as the Company, warrants its machines and related accessories, hereafter referred to as the Machine, to be free from defects in material and workmanship, for a period of twelve (12) months from the date of invoice to the first registered owner; this limited warranty does not apply to common wear items and excludes belts, shear pins, oil, grease, tires, tubes, hydraulic hoses, knives and PTO shafts.

Labor will be reimbursed at \$40.00 per hour based on BEFCO's time schedule.

Cost of transport to the servicing dealer is the responsibility of the customer.

Warranty coverage shall not be transferable from the first owner to any subsequent owner.

2. DISCLAIMER OF ALL OTHER WARRANTIES AND REMEDIES

Neither the Company nor any company affiliated with the Company makes any warranties, representations or promises, expressed or implied, as to the quality, performance or application of its products other than those set forth herein and does not make any implied warranty of merchantability or fitness.

The only remedies the purchaser has in connection with the breach, or performance of any warranty on the Company's Machine are those set forth herein. In no event will the dealer, the Company, or any company affiliated with the Company, be liable for:

- a. Injuries or damages of any kind or nature, direct, consequential or contingent to person or property.
- b. Any expenses incurred by the owner to repair, replace or rework any allegedly defective item.
- c. Any loss, cost, forfeiture or damages (including loss of profits; loss of crops; loss because of delay in field operations; any expenses or loss incurred for labor, supplies, substitute machine rental; liabilities of the owner to its customers or third persons; and all other consequential damages, losses, liabilities or damages for any other reasons) whether direct or indirect, and whether or not resulting from or contributed to by the default or negligence of the Company, its agents, employees and subcontractors which might be claimed as a result of the use or failure of the equipment delivered.

The Company's liability based on this limited warranty or any other applicable laws shall be limited to replacement or refund of the purchase price of the product.

The limited warranty extended herein gives you specific rights and you may also have other rights which vary from state to state. Neither the dealer nor the Company personnel has the authority to make any representation or to modify the terms and limitations of this warranty in any way.

Other than the limited warranty extended hereby there is no other expressed warranty in connection with the design, safety or use of any of the Company's products except as to title. All implied warranties are expressly disclaimed pursuant to the terms of this warranty.

3. CUSTOM WORK

If the Machine is used for commercial purposes such as custom work, the period warranted for the Machine is limited to six (6) months from the date of delivery to the first registered owner and does not cover any labor charges incurred.

4. RENTAL

If the Machine is used for rental purposes the period warranted for the Machine is limited to thirty (30) days from the date of delivery to the first registered owner and does not cover any labor charges incurred.

5. REGISTRATION

In order to qualify for coverage on this limited warranty, the product and name of the original purchaser must be registered with the Company by a completed Machine Pre-Delivery Checklist and Warranty Registration along with a copy of the dealer's invoice to the first registered owner to the Company within fourteen (14) days after the date of delivery to the original purchaser.

6. WARRANTY SERVICE

Warranty Service must be performed by a dealer authorized by BEFCO. If the warranty service requested is approved, the owner shall pay only for labor beyond the rate allowed, for overtime labor, and for any mileage charge for transporting the equipment to and from the dealer's shop. It is assumed that the dealer has the appropriate general and special tools to service the Machine. Time required for replacement of knives, oil, grease and to remove excessive dirt from the Machine is not subject to reimbursement by the Company. The owner is required to clean the Machine before presenting it to the dealer for service work. The Machine must be delivered within thirty (30) days after failure date by the owner to the dealer to be eligible for warranty consideration.

7. UNAPPROVED SERVICE OR MODIFICATION

All obligations of the Company under this limited warranty shall be terminated if:

- a. Proper service and operation instructions as outlined in the Operator's Manual and on the instruction sticker on the Machine, are not followed.
- b. The Machine is modified or altered in any way not approved by the Company.
- c. The Company does not receive a copy of the dealer's invoice to the first registered owner within fourteen (14) days from the date of delivery.
- d. The Company has not been paid in full, by the dealer, for the Machine.

8. ACCIDENTS AND NORMAL MAINTENANCE

This limited warranty covers defective material and workmanship. It does not cover depreciation or damage caused by normal wear, accidents, improper maintenance, improper protection or improper use. The costs of normal maintenance or repairs for accidents or improper use, and related labor will be borne by the owner.

9. REPLACEMENT PARTS

BEFCO, Inc. warrants replacement parts to be free from defect in material and workmanship for a period of thirty (30) days from the date of delivery to the original purchaser.

WARRANTY REGISTRATION

BEFCO, Inc.
P.O. Box 6036
Rocky Mount, NC 27802-6036

Tel: (252) 977.9920 - Fax: (252) 977.9718

Dealer _____ Acct. # _____	Retail Customer _____
Street _____ Country _____	Street _____
Town _____ State _____ Zip _____	Town _____ State _____ Zip _____
Date of delivery _____ Invoice # _____	Phone _____
Model # _____ Serial # _____	
<p>Pre-Delivery Checklist:</p> <p><input type="checkbox"/> Oil in gearbox.</p> <p><input type="checkbox"/> Greased fittings.</p> <p><input type="checkbox"/> Safety guards in place.</p> <p><input type="checkbox"/> All hardware tight.</p> <p><input type="checkbox"/> Bolts torqued correctly.</p> <p><input type="checkbox"/> Attached unit to tractor. Yes/No.</p> <p><input type="checkbox"/> Field adjusted. Yes/No.</p> <p><input type="checkbox"/> Test run. Dry/Infield.</p> <p><input type="checkbox"/> Safety decals.</p> <p><input type="checkbox"/> Operator's Manual.</p> <p>The machine described above, had been prepared for delivery according to the Pre-Delivery Checklist and the Customer has been instructed in its care and operation and the condition of warranty.</p>	<p>Tractor make: _____</p> <p>Model: _____; HP _____</p> <p>Type of operation: Private homeowner, Landscaping, Commercial maintenance, Golf Course, Municipality, Turf Farm, others: _____</p> <p>Approximate number of acres machine will be used on annually: _____</p> <p>I hereby acknowledge that: I have received and accepted delivery of the machine described. The equipment was checked thoroughly for loose or missing parts and has been adjusted in accordance with the Pre-Delivery Checklist. I have read and understand the nature and extent of the warranty and understand clearly that there were and are no other representations of warranties either expressed or implied, made by anyone. I have been advised on proper operation, maintenance and lubrication procedure of this equipment. I have been instructed on and do understand the application, limitation and capacities this equipment was designed and recommended for, all as described in the Operator's Manual and literature published by the Company.</p>
Inspected by: _____	
Date: _____	Date: _____
Dealer's Signature: _____	Customer's Signature: _____

This registration along with a copy of the invoice must be sent to BEFCO, Inc. within 14 days of date of purchase.

Sender:

Fold here

*Place stamp
here*

BEFCO, Inc.

Warranty Department

P.O. Box 6036

Rocky Mount, NC 27802-6036

Cut along this line

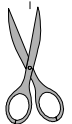

Use only original spare parts

All rights reserved. It is unlawful to copy, reprint or use any of the information or details in this manual without the expressed written permission of the Company. Technical information provided in this manual is approximate, the Company reserves the right to modify or improve the models shown for technical or commercial purposes. Pictures in this manual do not necessarily show the machine as delivered.

BEFCO[®]

P.O. Box 6036
Rocky Mount, NC 27802-6036
Tel.: 252.977.9920 - Fax: 252.977.9718
www.befco.com

